



AI simulated image of the MDLR-J5

PAYLOAD 5,000 kg water / retardant	RUNWAY 1,000 m (short field)	BASE ALTITUDE up to 2,500 ft (Galician airfields)	MAX TEM ISA +25°	RANGE 500 km (round trip)	CREW 2 pilots + 1 load master
---	---	--	----------------------------	--	--

1. PROBLEM DEFINITION

MISSION & CONTEXT

Recent wildfire seasons in northwest Spain (Galicia) have overwhelmed existing aerial resources, burning over **120,000 hectares**, forcing **evacuations**, destroying **homes**, and causing severe **environmental** and **societal** impacts.



The **MDLR-J5** addresses this by enabling **rapid-response**, **high-frequency** aerial drops to contain fires **early** and **improve** suppression effectiveness.

OPERATIONAL SCENARIO



Galicia, Spain

- Regional airports** and temporary forward strips.
- Water/retardant** delivery on active wildfires.
- Rapid turnaround**: refill in ~10 mins.
- Typical Operation**: ~7 sorties/day (100 km nominal radius, 12 hr ops).
- Crew**: 2 pilots + 1 load master.

REQUIREMENTS

- Operating Altitude**: 150 ft (Drop), 5,000 ft (Cruise).
- Operational (service) ceiling**: 20,000 ft
- Takeoff Distance** (SL, ISA+25°C): 1,000 ft.
- Landing Distance** (SL, ISA+25°C): 1,000 ft.
- Ambient Environment** for sizing: ISA +20°C at 3,000 ft

2. DESIGN CALCULATIONS AND ANALYSIS

DATA / SUMMARY	
Aircraft Category	Regional turboprop
W_{To} (TOGW)	31980 lb
W_E (Empty Weight)	18998 lb
W_F (Fuel Weight)	1560 lb
W_P (Payload Weight)	11000 lb
Power Loading (P/W)	0.1393 hp/lb
Wing Loading (W/S)	30 lb/ft ²
Power Required	4,455 hp
Specific fuel consumption (SFC)	0.470lb/shp/hr
Growth Factor	2.80

MISSION PROFILE

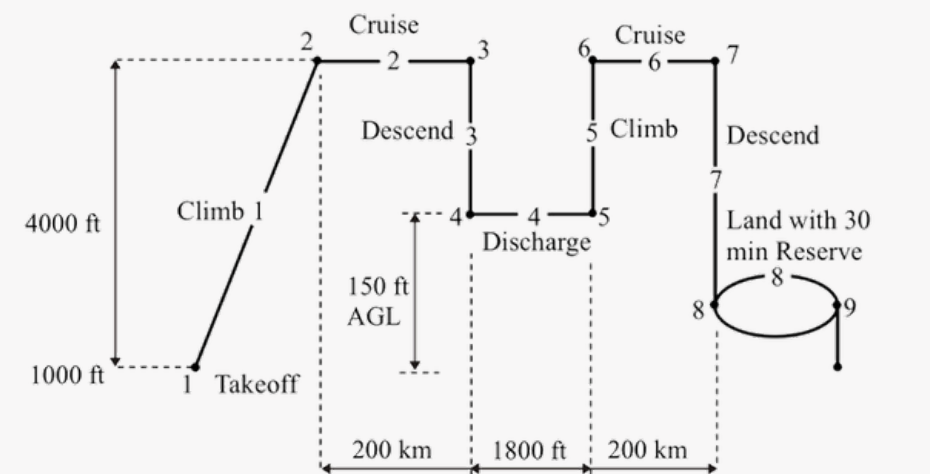

FUEL FRACTIONS		
Segment	Fuel Fraction	Cumulative Fuel Fraction
1) Taxi	0.99930	0.99930
2) Climb	0.99942	0.99872
3) Cruise	0.98105	0.97980
4) Discharge	0.99993	0.97973
5) Climb	0.99944	0.97918
6) Cruise	0.98105	0.96063
7) Descend	0.99975	0.96039
8) Loiter	0.99057	TOTAL: 0.95133

-SELECTED WING LOADING AND SPECIFIC POWER

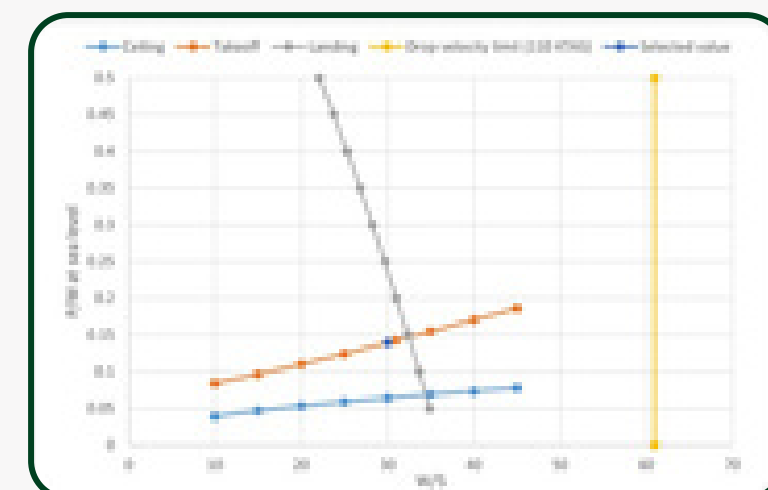

To select the values for both **W/S** and **P/W** we chose a point that lied within the range of the three scenarios (in the upper left region) in **W/S= 30** and **P/W= 0.1393**

1) WING	
Aspect Ratio (A)	7
Taper Ratio (λ)	0.9
Quarter Chord Sweep	2.76
Airfoil	NACA 2412
Aileron Area / Wing Area	0.049
Fuel tank capacity	780 lb

2) FLAPS	
Single-Slotted TAKEOFF (δ = 12°)	
ΔCL _{max}	0.3368
ΔCD ₀	0.0069
LANDING (δ = 18°)	
ΔCL _{max}	0.5052
ΔCD ₀	0.0165

3) EMPENNAGE	
Aspect Ratio (A)	6.78
Taper Ratio (λ)	0.553
Quarter Chord Sweep	9.6°
Airfoil	0012
Control Surface / Tail surface	0.278 (elevator) 0.287 (rudder)
Tail Volume	0.339
HORIZONTAL	VERTICAL
L _t / MAC = 2.21	L _v / b = 0.272

4) GEAR SIZING	
CG Height (H_{CG})	77.3 in
Static Load (P_w)	2,751 lb (NOSE) 31,419 lb (MAIN)
Gear Location	FS 66 in (NOSE) FS 323.1 in (MAIN)
Tire	DUAL 8.5-10 (NOSE) DUAL 15-16 (MAIN)
Tire Diameter	25.7 in (NOSE) 42.4 in (MAIN)
Track	336 in (MAIN)
Shock absorber stroke	6.22 in (NOSE) 5.24 in (MAIN)

5) MASS PROPERTIES	
Longitudinal cg range: %26	
Vertical CG Migration	

AERODYNAMIC PARAMETERS	
Clean zero lift drag	0.033
Maximum Lift coefficient	1.4
Oswald Efficiency	0.8
Landing gear drag increment	0 (fixed gear)
Propeller Efficiency	0.75
Induced drag factor (K)	0.0568

ENGINE SELECTION: TWIN ENGINE
Pratt & Whitney Canada PW123 • Engine power: 1,230 hp
 • Installed power: 4,760 hp
 • Engine weight: 1,000 lb
 • Size: 84x33 in
 • Number of blades: 4
 • Inlet capture area: 2.32 ft²

Component	Weight
Fuselage wgt	3542
Wing Wgt	3799.6
Left	1899.8
Right	1899.8
Empennage Wgt	837.2
Hor Stab	444.36
Left	222.18
Right	222.18
Vert Stab	394.128
Nacelle Wgt	547.4
Landing Gear Wgt	1674.4
Main Gear	1172.08
Left	586.04
Right	586.04
Nose Gear	502.32
Propulsion Wgt	3735.2
Fixed Equip. Wgt	4862.2
Empty Wgt	18998
Crew	630
Pilot	630
Luggage	0
Operational Empty	19628
Fuel	1560
Fully fueled:	21188
Cargo	11000
Pax1	11000
Pax2	
Pax3	
Luggage	
TOGW	32188
Landing Weight:	30628

3. FINAL DESIGN

All units are in inches.

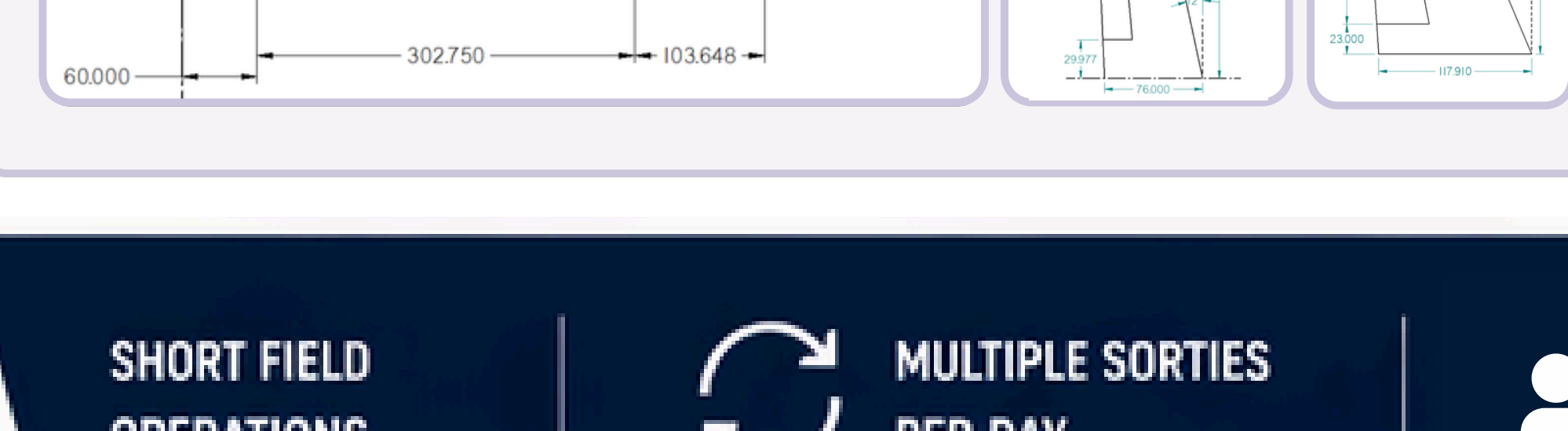
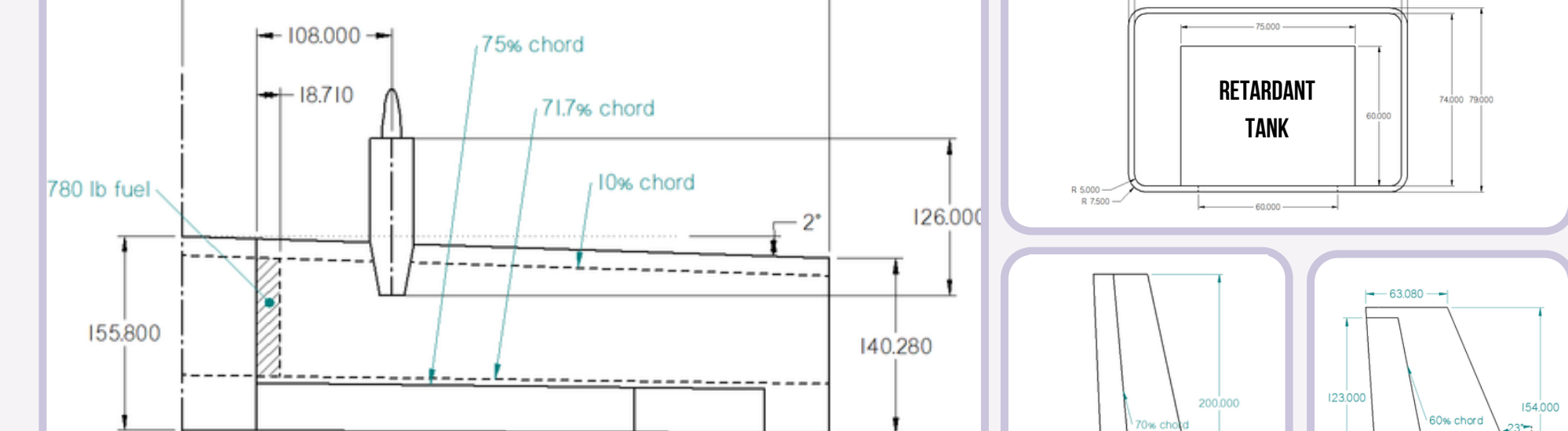
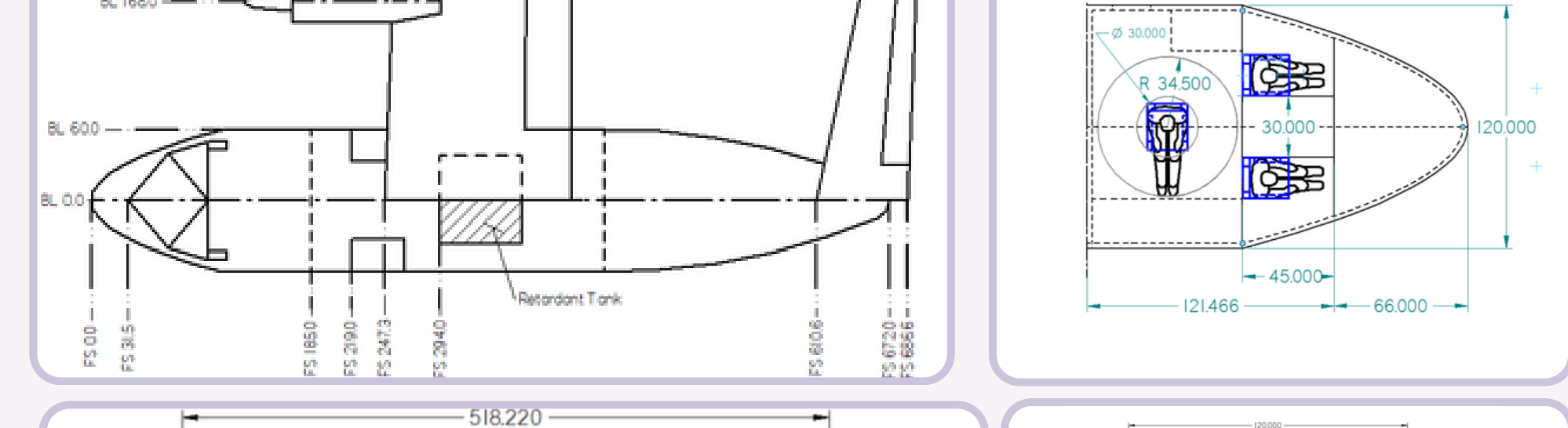
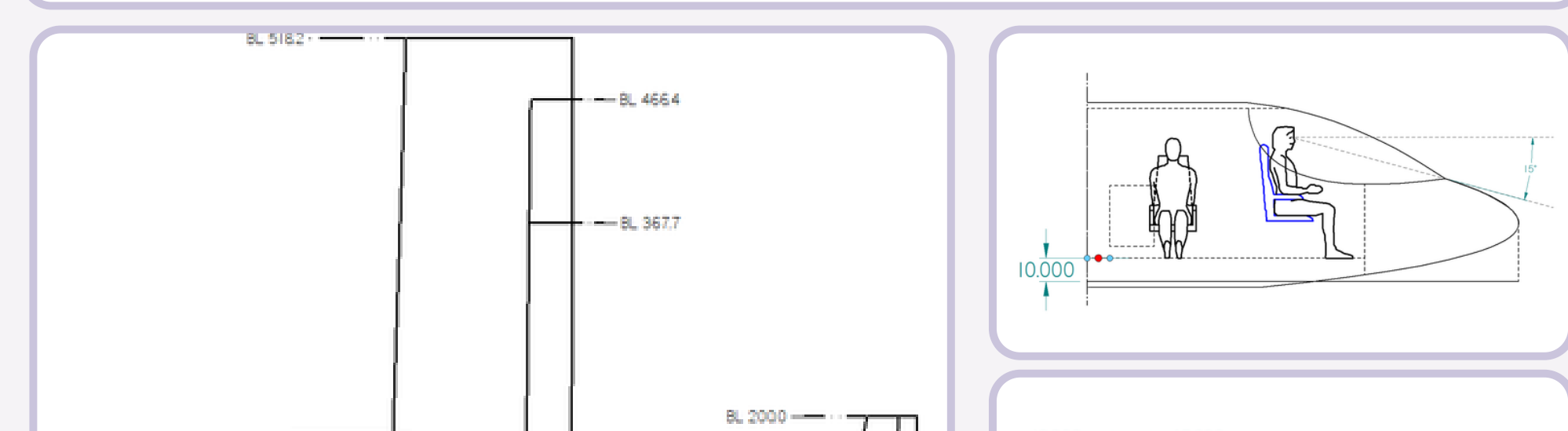
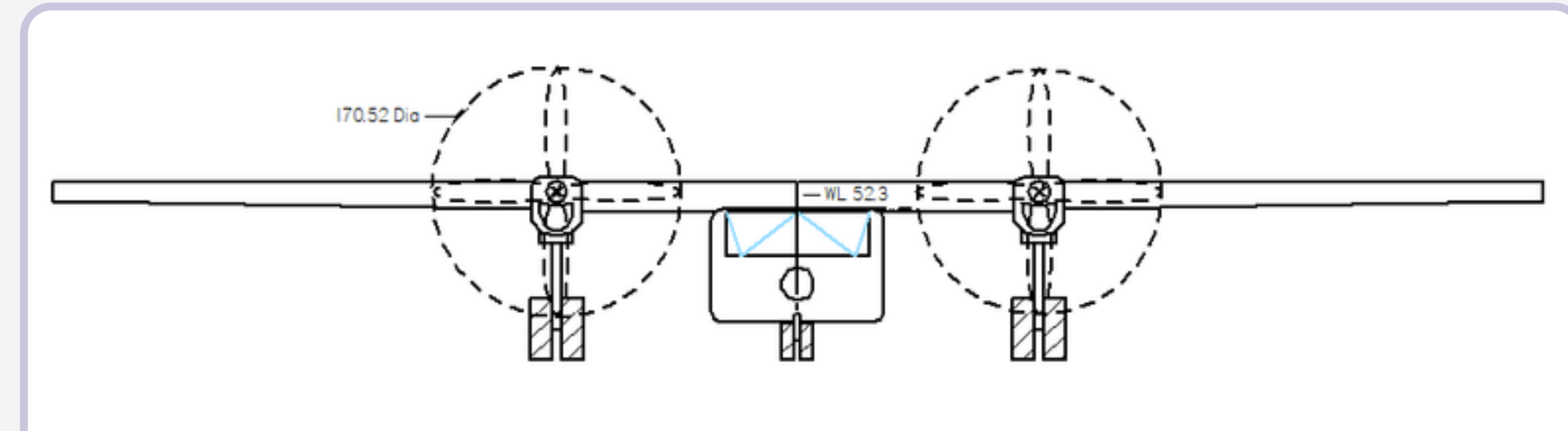
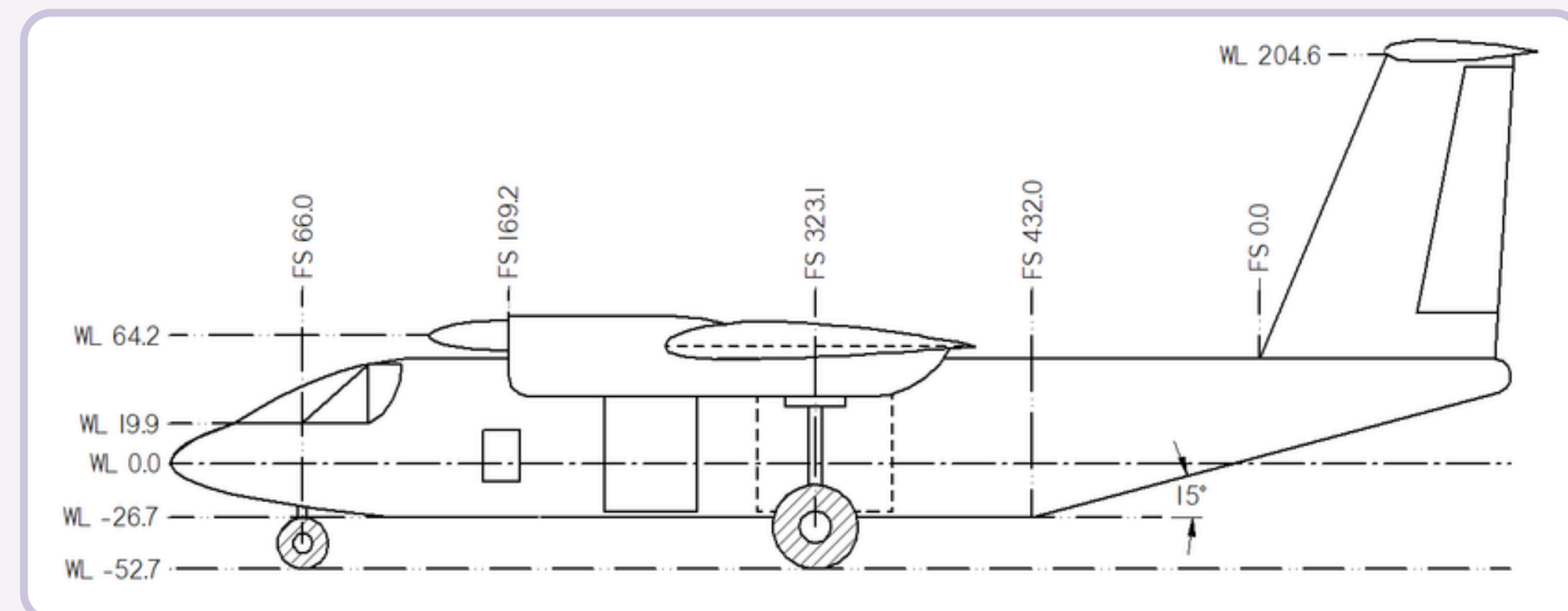

4. TEST RESULTS; VALIDATION

PERFORMANCE VERIFICATION
 Takeoff, climb, cruise and ceiling requirements are met with a margin in T/W and an efficient W/S, giving a balanced airplane.

MISSION VERIFICATION
 Mission profile completed with a total fuel fraction of 0.95133. There is enough fuel capacity for larger missions if needed.

SAFETY & RELIABILITY
 The airplane was inspired by the C-212. Regarded as a highly reliable, sturdy, and versatile workhorse, designed for operations in harsh environments

COMPARISON WITH HISTORICAL DATA
 The airplane has been designed with parameters inside historical values for regional turboprops (comparison below).

PARAMETER	MDLR-J5	TYPICAL RANGE
Aspect Ratio (A)	7	7 - 10
Zero-lift drag coefficient	0.033	0.022 - 0.035
Oswald efficiency (e)	0.8	0.75 - 0.82
Clean CL_{max}	1.4	1.2 - 1.5
CL_{max}(takeoff)	1.7368	1.7 - 2.0
Wing Loading (W/S)	30 lb/ft ²	25-35 lb/ft ²



AI simulated image of the MDLR-J5