

Modernizing the Process Design of Acetylsalicylic Acid Production

Maliha Jahan, Hannah Ellenbogen, Shirin Haan, Alayna Sheahy

Dept. of Chemical & Biomolecular Engineering



Optimizing DIB Tower Sustainability

The current design of traditional Deisobutanizer towers is expensive and requires high usage of utilities. We want to make the process more environmentally and economically sustainable. With heat integration and economic management of the various processes within the unit, we were able to end with a profit of **745.98 million dollars** with a pay back period of **4.48 years**. Our Carnot efficiency was **5.77%** with the thermodynamic efficiency of **19.88%**.

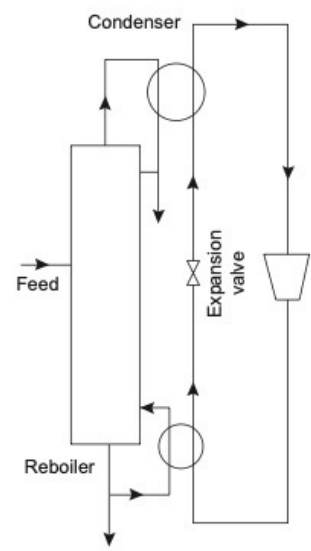

Figure 1. Towler and Sinnott, 2nd ed

Aspirin Production Process

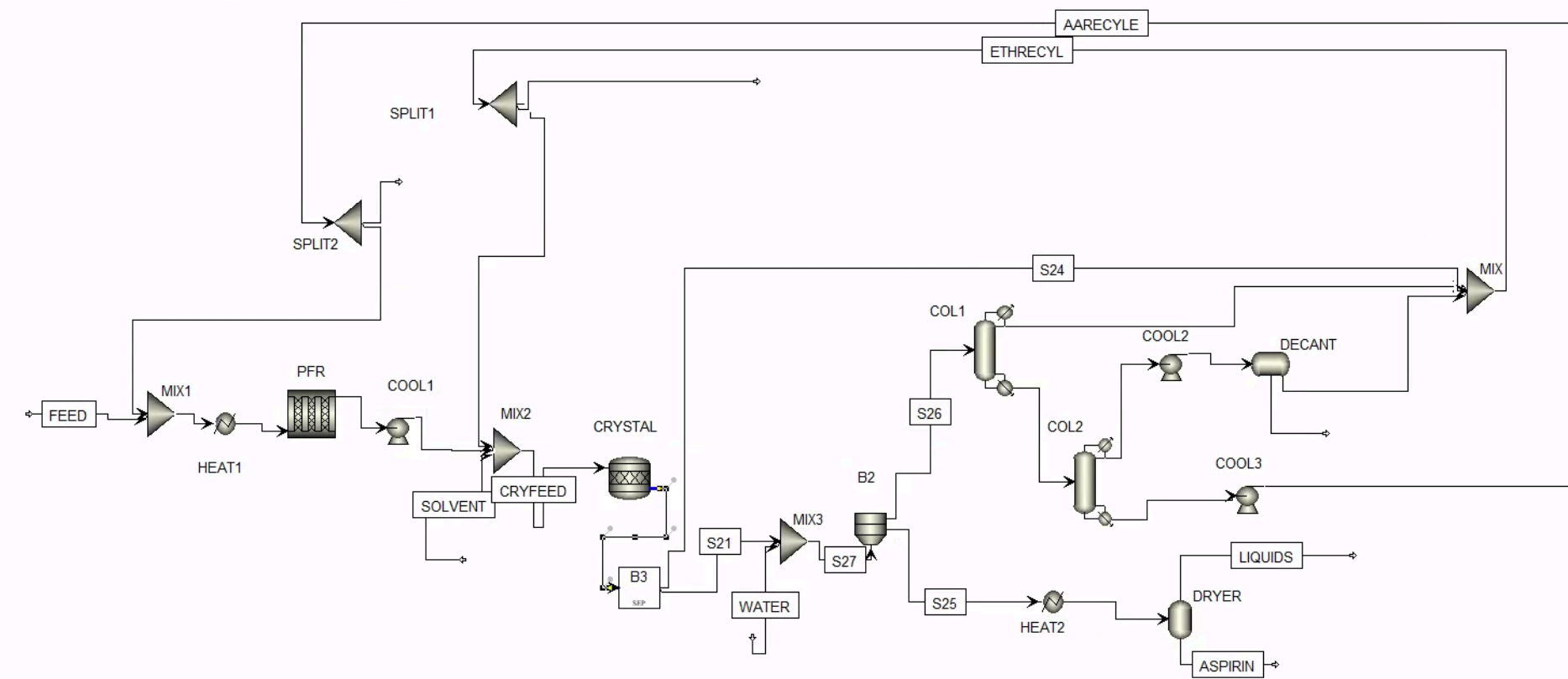
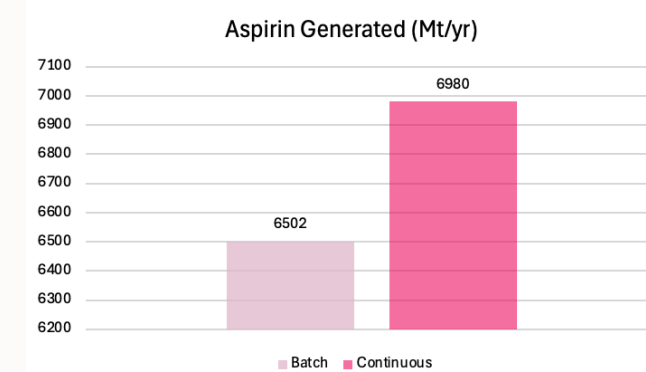

Figure 3. Process Flow Diagram for the Process of Aspirin Manufacturing

Project Description



The product contains no less than **99.5%** acetylsalicylic acid. The manufacturing process follows FDA and state regulations for drug manufacturing. The feed stream consists of acetic acid combined with salicylic acid and acetic anhydride. The feed reacts in the continuous reactor (PFR) and is subsequently crystallized with a solvent and an anti-solvent. The product is centrifuged and dried to recover the product, acetylsalicylic acid (aspirin). Recovered acetic acid from the crystallization process is recycled into the feed stream. Recovered solvent from the centrifuge and drying process is recycled into the crystallization process.

Decarbonization Strategy

Strategy 1: Recycle Streams

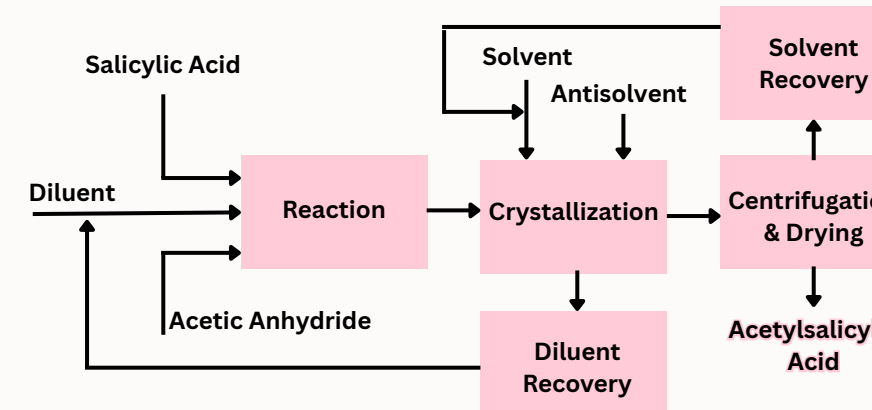

Figure 4. Basic Functional Block Diagram for the Process of Aspirin Manufacturing

We are implementing two recycle streams into our process. The first recycle stream comes from the centrifugation step. It recycles acetic acid waste to be reused in the feed for the continuous reactor. The second recycle stream comes from the crystallization step. It recycles ethanol to be reused as solvent for the crystallizer.

Strategy 2: Continuous Reactor

The second decarbonization strategy for our process is replacing the common batch reactor with a continuous reactor. This switch has many advantages for sustainability.

Economics

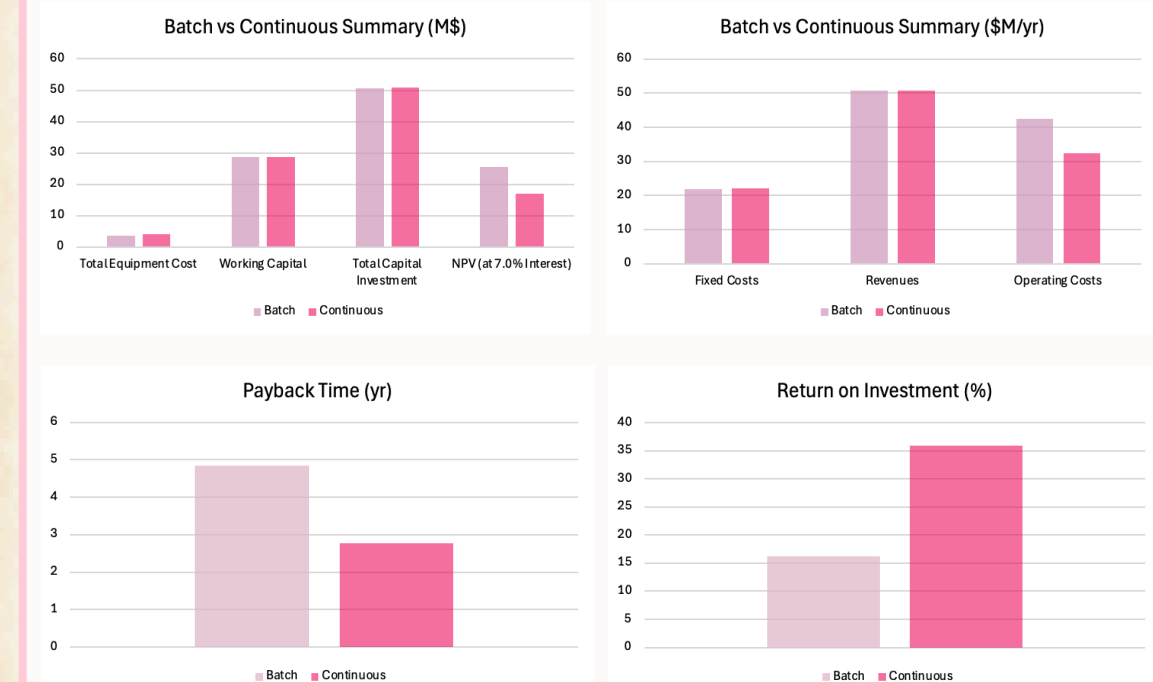

Compared to the base case batch reactor Aspirin production design, the economics do not severely differ. The Net Present Value (NPV) of the continuous reactor after one year is about **\$17.1 million**, compared to \$25.6 Million for the base case. However, considering the environmental benefits, we can conclude that the continuous reactor design would be economically viable.³

Introduction

The current process of producing acetylsalicylic acid (aspirin) is outdated and generates hazardous waste. Most pharmaceutical production processes generate anywhere from **25 to 100 kg of waste per kg of product**.¹ This waste is a serious environmental and economic concern, as it contains valuable materials along with toxic materials.

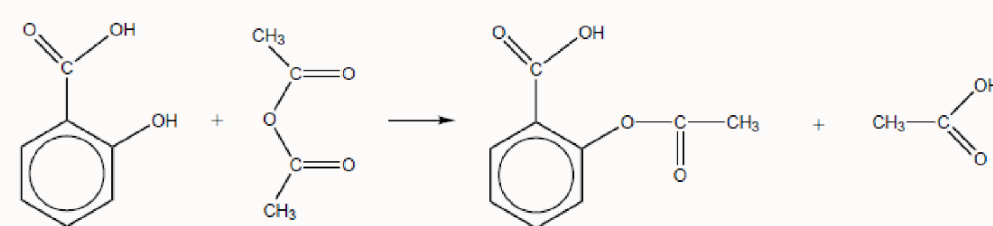

Figure 2. Acetylsalicylic acid (Aspirin) synthesis reaction³

GSK, a pharmaceutical company in **Rockville, MD** has a manufacturing plant which previously produced aspirin. However due to current sustainability goals and supply chain issues, the product has been halted.² GSK plans for waste reductions does not identify by which measures they plan to reduce waste production in their supply chain.²

Sustainable Impact

Our continuous reactor reduces water usage by **25.4%** compared to the base case design of a batch reactor. Our design produces no more than **20 ppmv** of hazardous air pollutants in the outlet concentration. Along with **2,100 MT/year** of carbon dioxide emitted from our facility. This is significantly below the value of 25,000 MT/year that would need to be reported to the EPA.

References

- Welcome To Zscaler Directory Authentication. Worldpharmatoday.com. <https://www.worldpharmatoday.com/production-manufacturing/sustainable-chemical-processes-in-drug-manufacturing/>.
- GSK. Materials and waste | GSK. [www.gsk.com. https://www.gsk.com/en-gb/responsibility/environment/materials-and-waste/](https://www.gsk.com/en-gb/responsibility/environment/materials-and-waste/).
- Petrides, D.; Mustafa, A.; Misailidis, N.; Stylianos Kontovas, S. Aspirin Production – Process Modeling and Techno-Economic Assessment (TEA) Using SuperPro Designer; 2023.