



Problem Definition

Natural disasters can destroy roads, bridges, and infrastructure, leaving communities isolated from emergency aid. This creates a need for Short Takeoff and Landing aircraft that can deliver supplies to remote or damaged areas where conventional transports cannot operate. Our aircraft is designed to support disaster relief missions for organizations such as FEMA, NATO, the United Nations, the Red Cross, military groups, and humanitarian relief agencies.

Requirement Category	Requirement
Mission Role	Post-disaster rapid-response aircraft
Primary Function	Deliver critical supplies and evacuate victims
Operating Environment	Damaged or destroyed transportation infrastructure
Target Locations	Remote communities isolated from logistics hubs
Disaster Types	Earthquakes, landslides, wildfires, and storms
Aircraft Capability	STOL performance for short/rough terrain operations
Configuration	High-wing, single-engine turboprop aircraft
Design Goal	Reach areas inaccessible to standard transport aircraft

Final Design

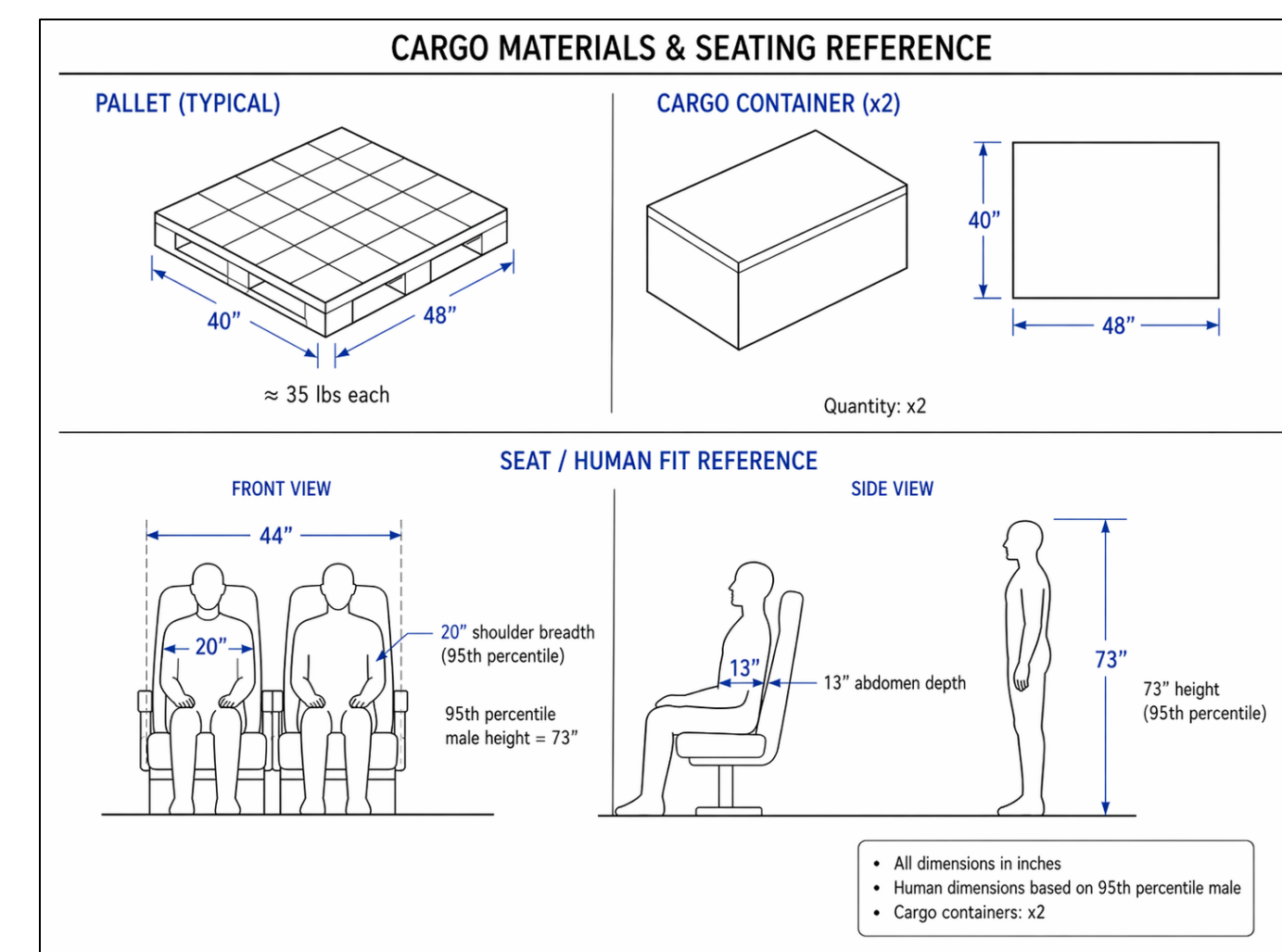

Cargo View

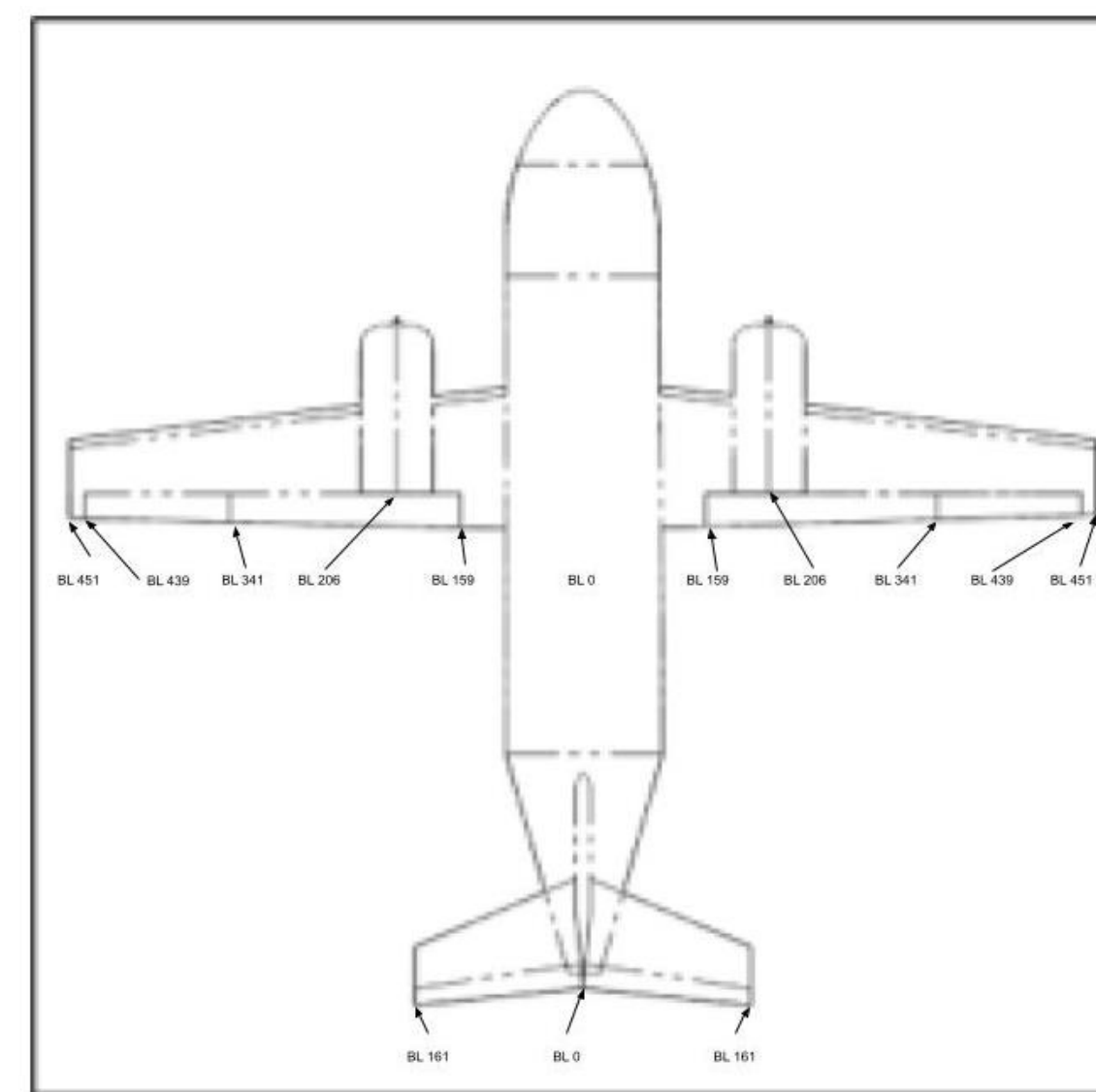

Top View, Overall

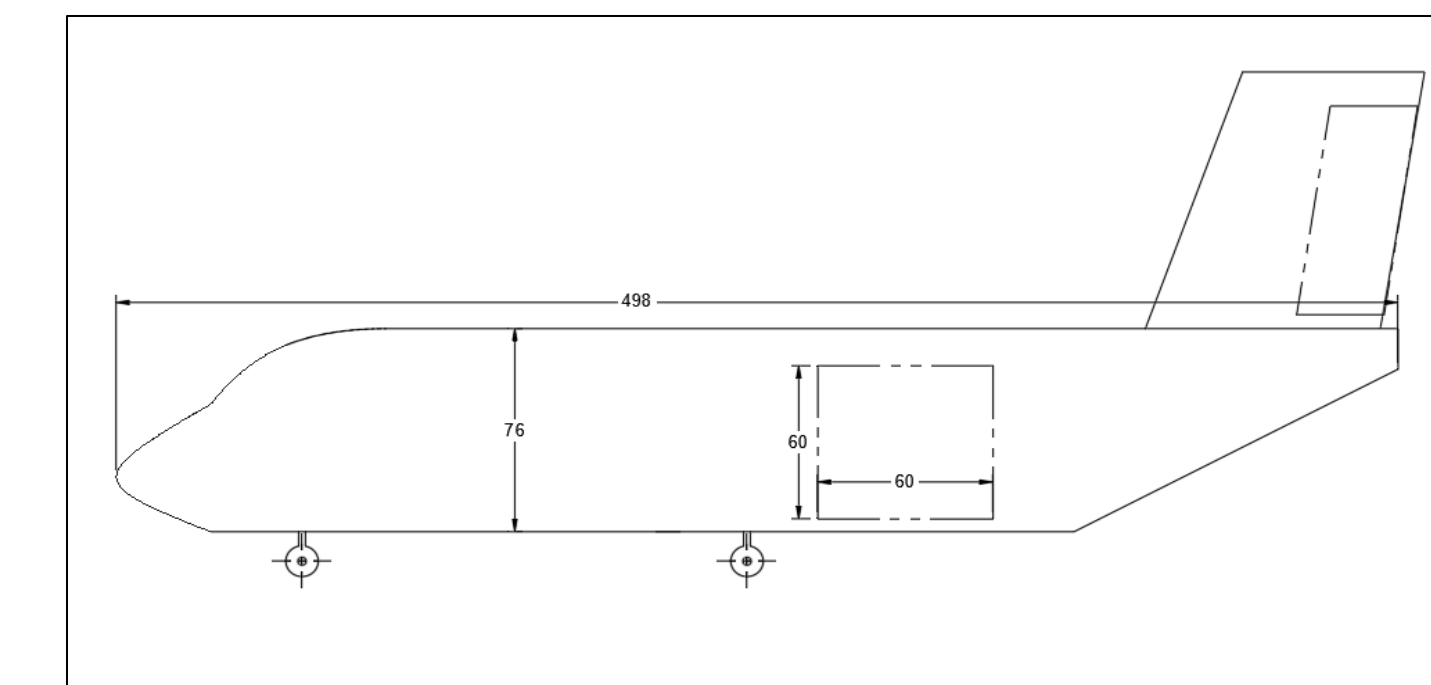

Side View, Payload Drop Door

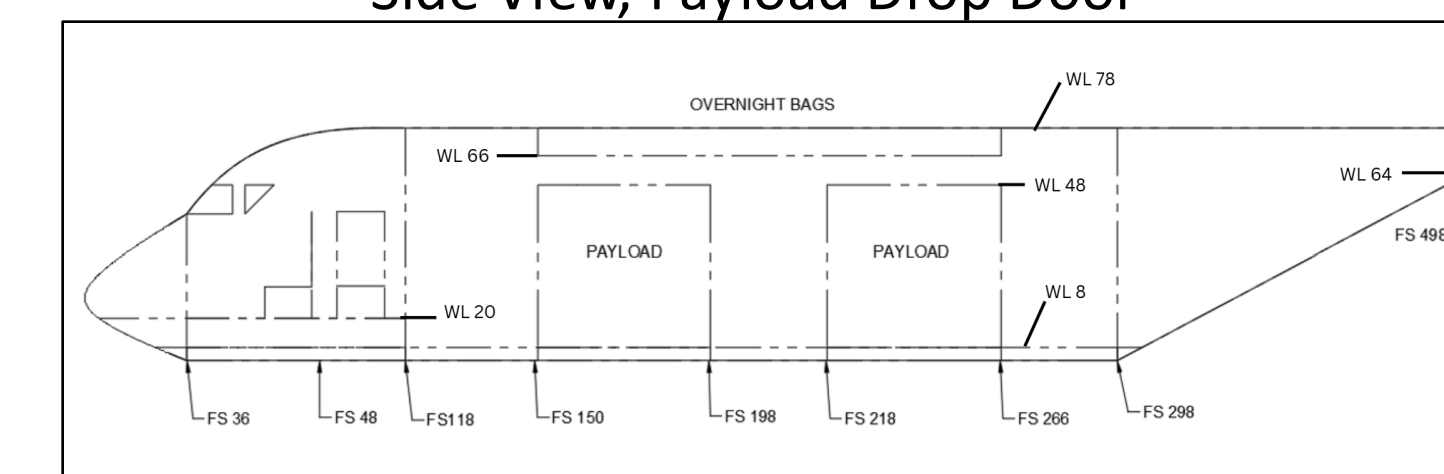

Side View, Overall

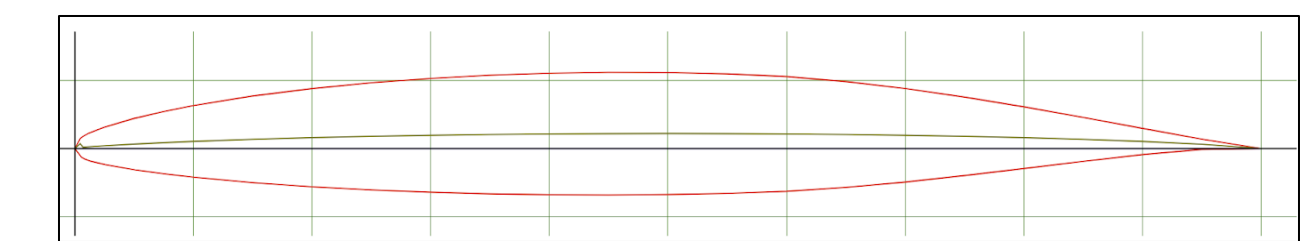

NACA 66-209 Airfoil

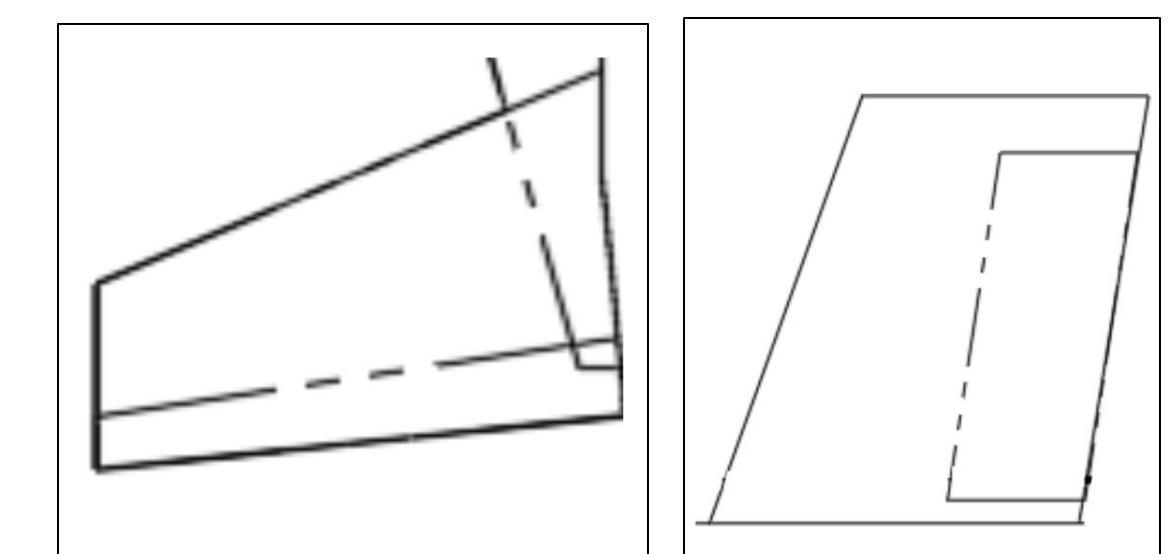

Horizontal and Vertical Stabilizers

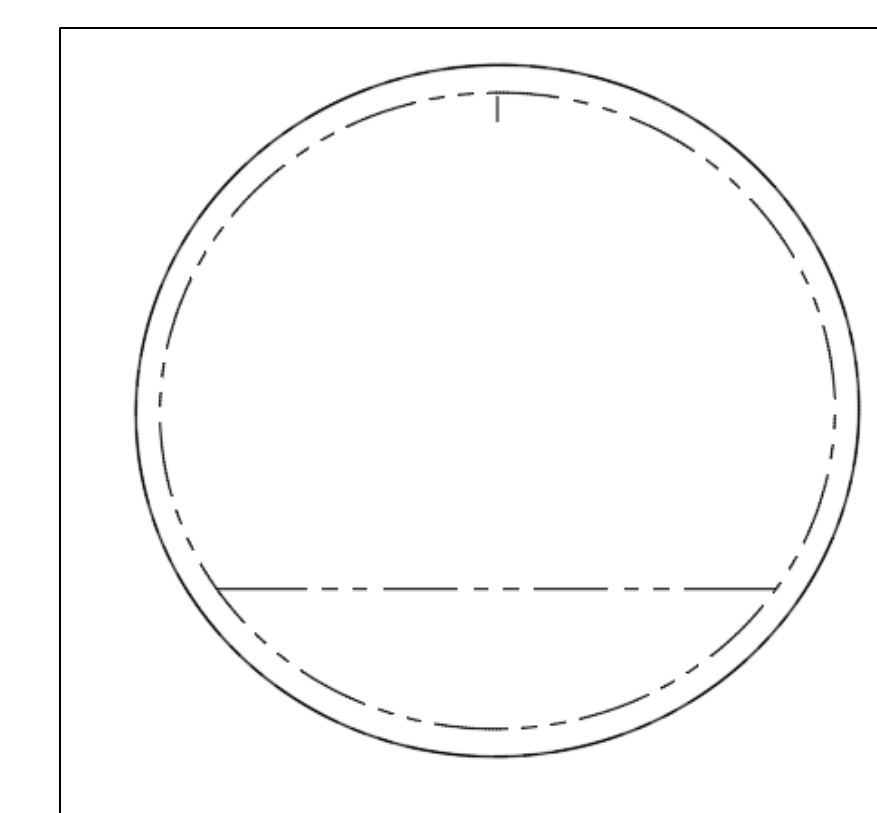

Cross-Sectional Fuselage View

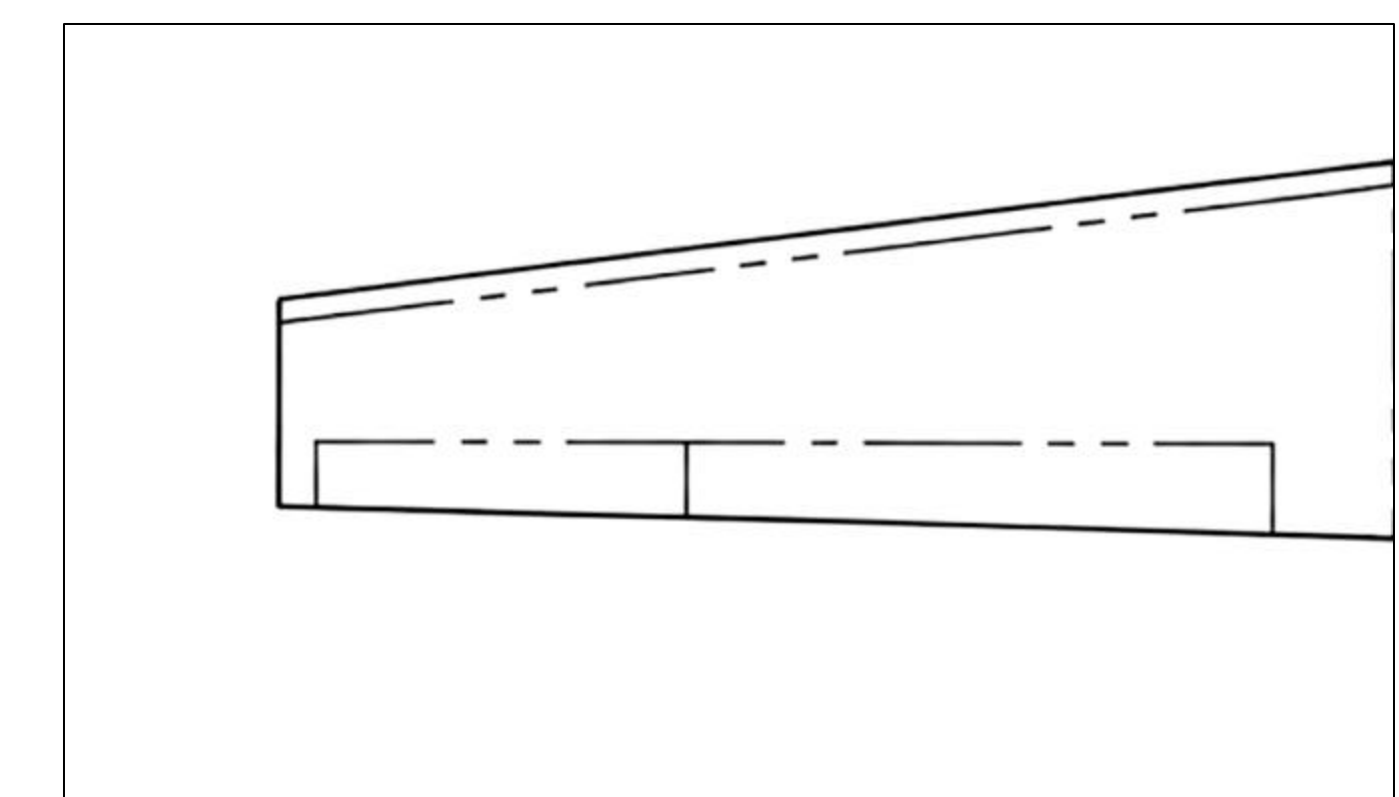

Top View, Wing

Design Calculations & Analysis

Weight Parameters	Pounds	Weight Calculations	Values
Fuel Weight	1,538	W_F/W_TO	0.181
Payload Weight	1,706	Growth Factor	4.983
Empty Weight	5,256	Risk	Low
Take-off Weight	8,500	Within Historical Range?	Within Range

Wing Parameters		Engine Parameters	
Wing Area	566.4 ft	Specific Fuel Capacity	0.65 lb/HP/hr
Wing Span	68.7 ft	Power (per engine)	400 SHP
Aspect Ratio	10	Propeller Efficiency	0.85
Specific Power Req.	0.18	Engine Type	Turboshaft
Wing Loading	15 lb/ft ²	Flap Parameters	
Taper Ratio	0.75	Max Lift Coefficient (Takeoff)	0.9
Mean Aerodynamic Chord	5.24 ft	Max Lift Coefficient (Landing)	1.6

Empennage Design			
Vertical		Horizontal	
Aspect Ratio	6	Aspect Ratio	5
Quarter chord Sweep	15°	Quarter chord Sweep	10°
Taper Ratio	0.6	Taper Ratio	0.8
Rudder Area/Tail area	0.33	Elevator area/Tail area	0.31
Lv/b	0.4	Lh/(MAC)w	3.75

WTO (lbs)	Main Gear				Nose Gear			
	$D_t X b_t$	$2P_m/W_{TO}$	PSI	n_{mt}	$D_t X b_t$	P_n/W_{TO}	PSI	n_{nt}
800	22x6.5	0.88	75	1	17x6	0.12	40	1

Prototype & Test Results

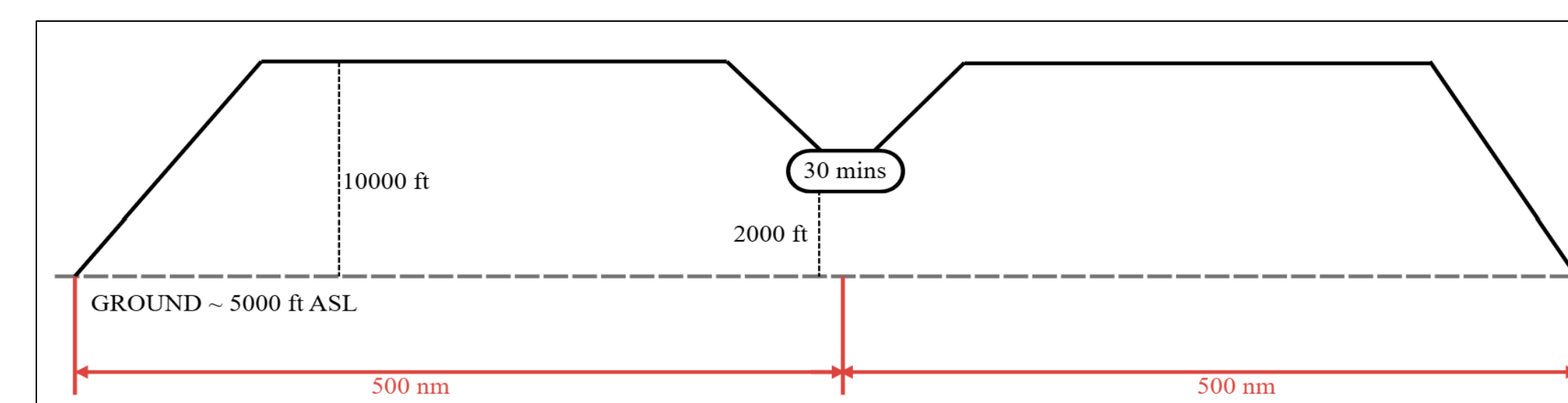

Mission Profile

Item	Quantity	Unit Weight	Subtotal (lb)
Crew	3	200	600
Generator	2	120	240
Water Purifier	22	6	132
Tents	4	30	120
First Aid Kits	12	6	72
Rotary Saw	2	30	60
Luggage	3	30	90
Flashlights	10	1	10
Water gallon	4	8	32
100 Meals	100	2	200
Pallet	2	35	70
Parachute System	2	25	50
Aid Packaging Shell	2	15	30
			1706

Cargo Specifications

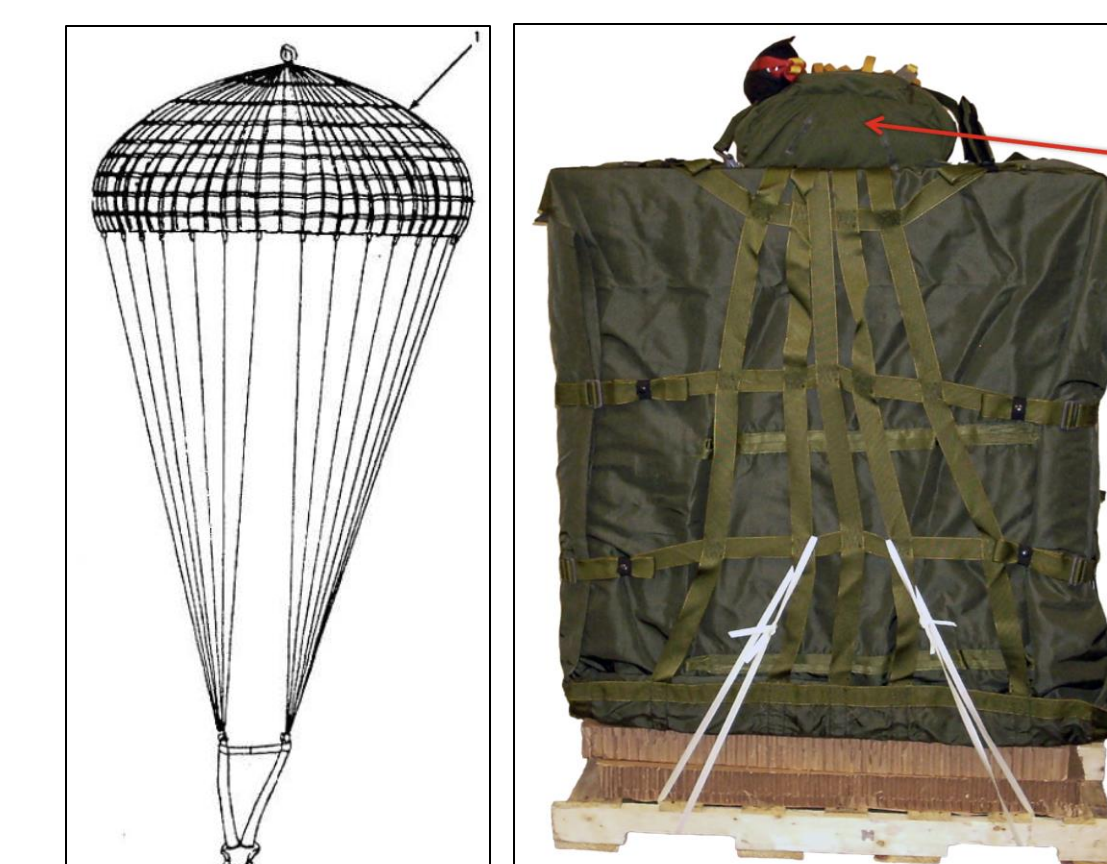

G-10 Cargo Delivery System

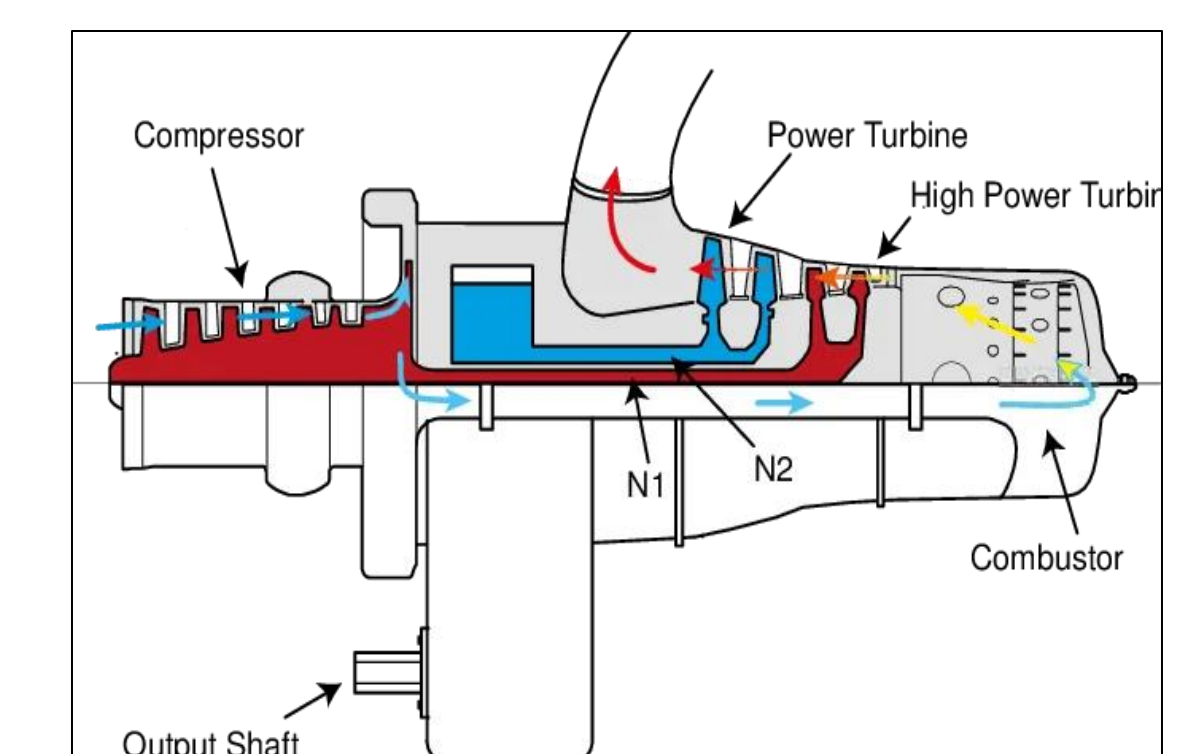
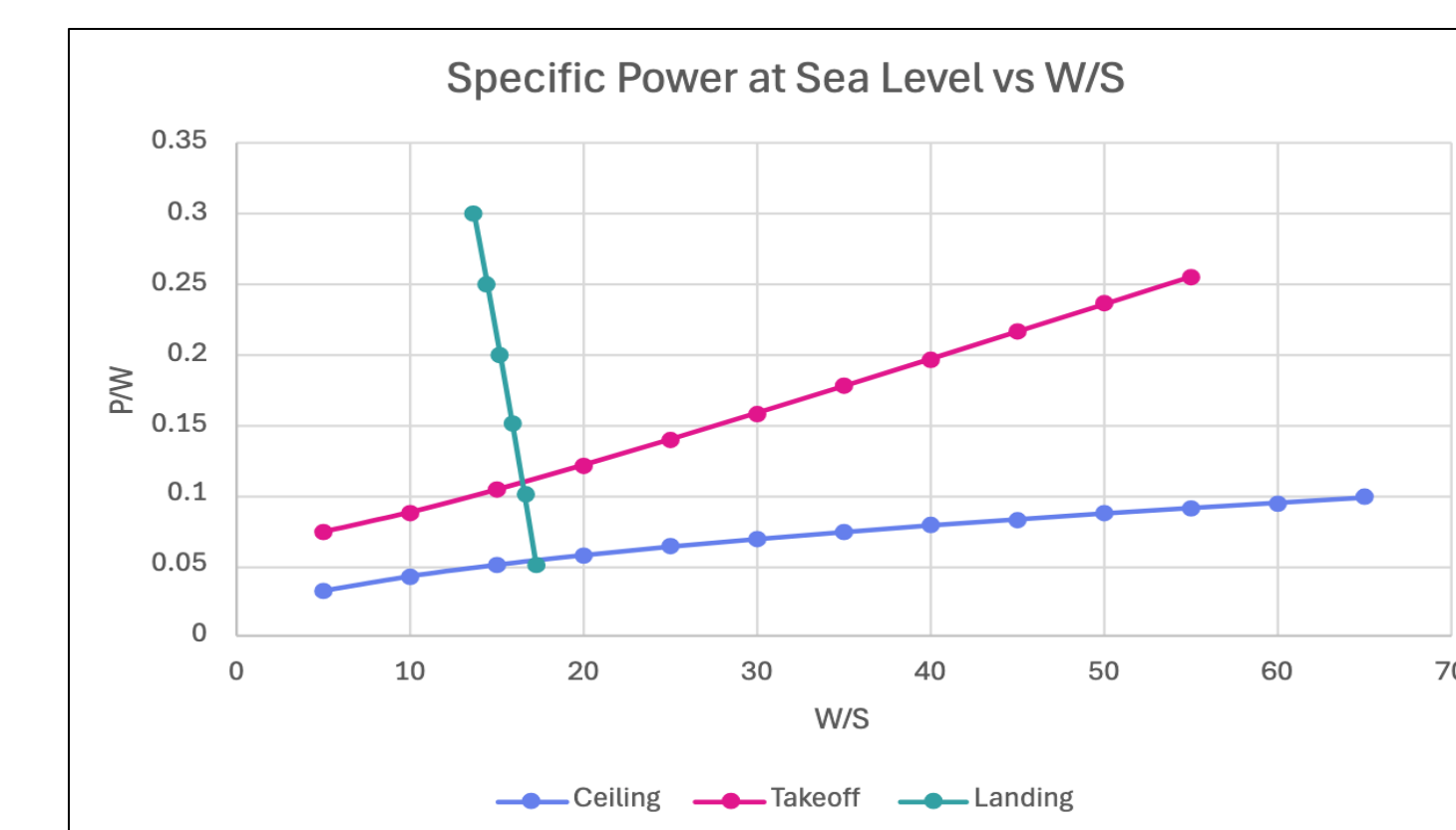

Allison 250-C20 Engine