

Motivation, Goal, Impact

- **Motivation:** About 10,000 people lose their lives in earthquake related disasters every year. Victims are often trapped in hard to reach areas and need to be evacuated as soon as possible
- **Goal:** Design a portable, deployable bridge for first responders in earthquake rescue situations
- **Impact:** Increase speed of rescues by providing a faster way for rescuers to traverse obstacles

Requirements

- Traverse many obstacles, such as rubble piles, flooding, and sinkholes
- Deployable by two or fewer first responders
- Foldable for transport and storage
- Support loads of at least 1000 lbs
- 10 ft length, 3.3 ft width
- 2 ft ground clearance
- Bridge weight < 300 lbs

Final Design

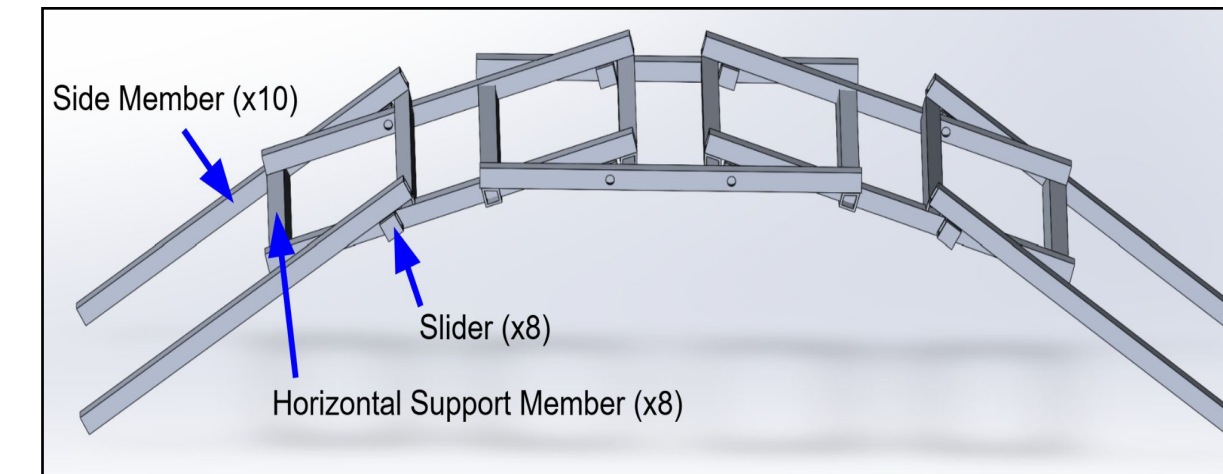

Folding Structure
Two sides made of five individual members each, connected by eight horizontal support members. Members connected by sliding joints for folding.

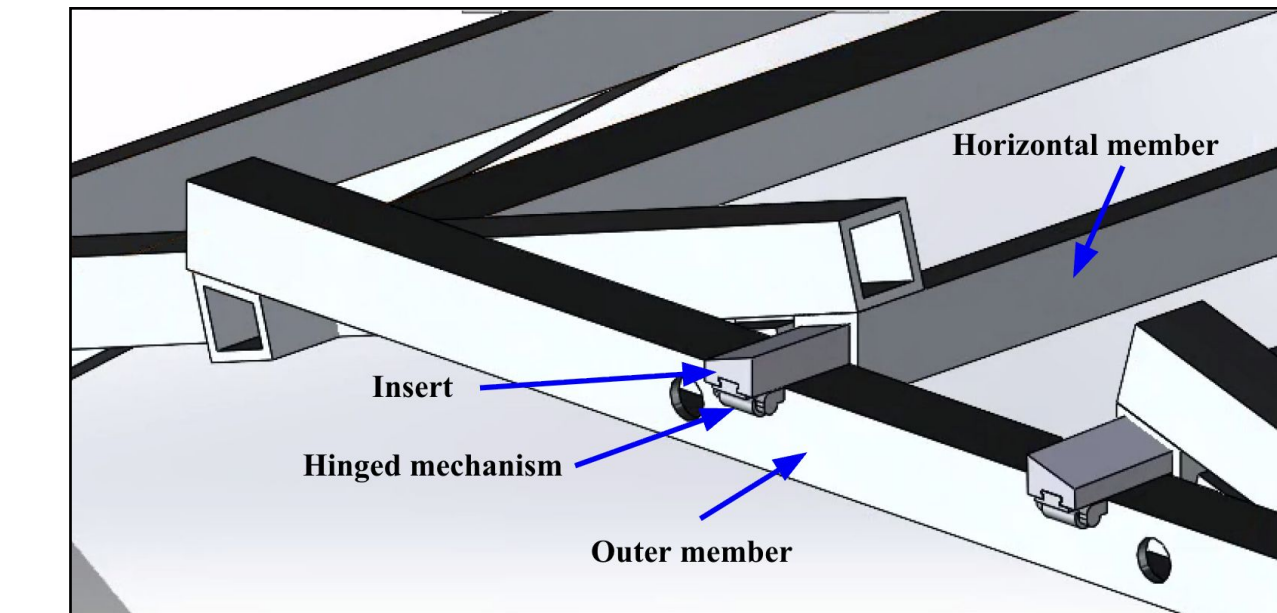

Joint Locks and Hinge:
Connect and prevent the motion between bridge members

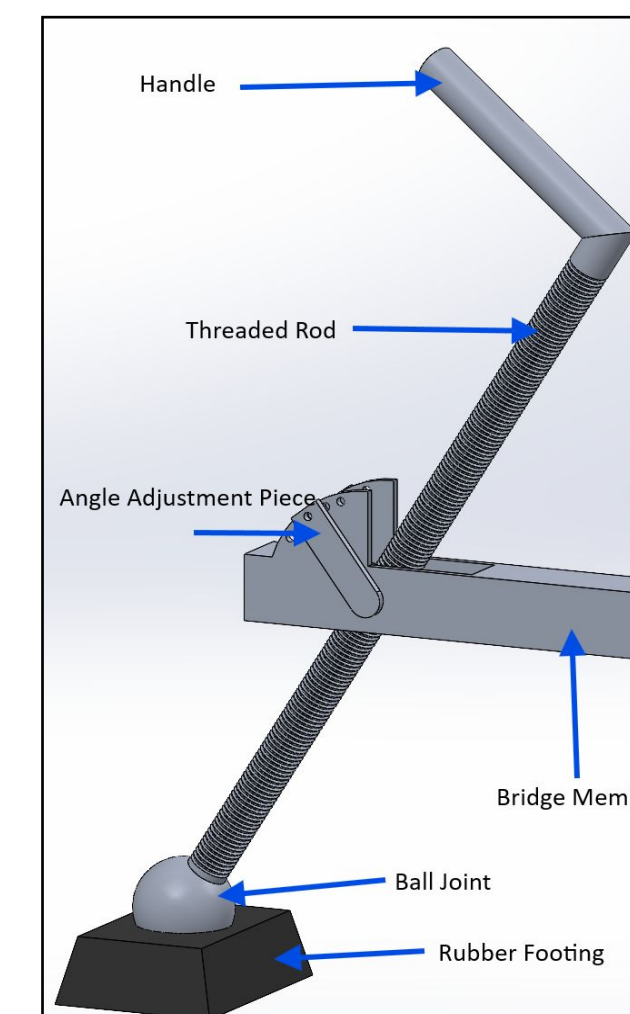

Footing:
Height and angle adjustment for the bridge, moving up and down the structure as desired

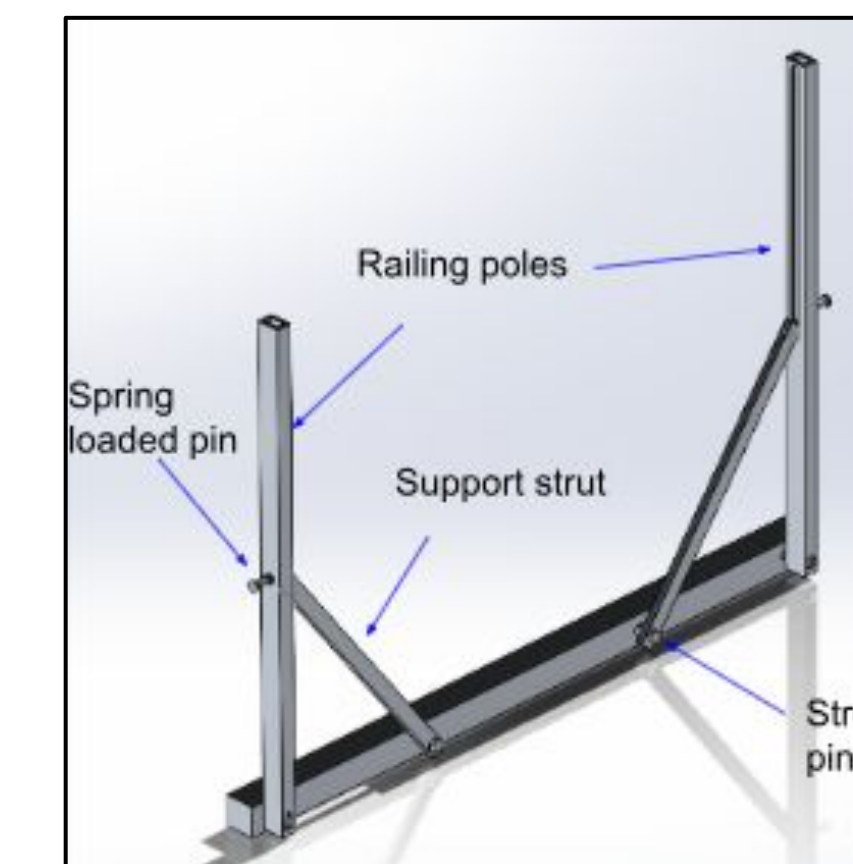

Railing System:
Safety net for users to prevent falling off, provides additional stability

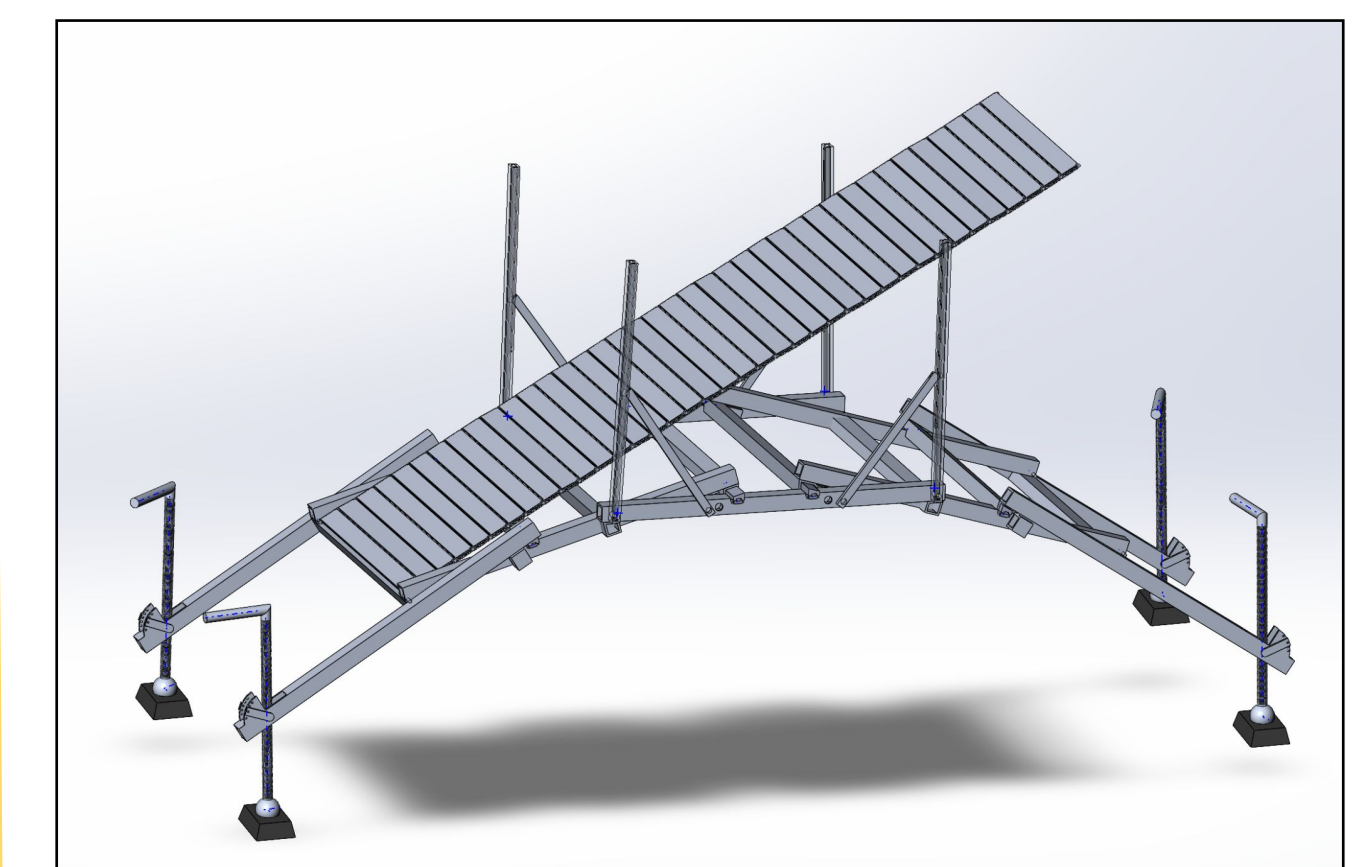

Final Assembly Model
Rolled deck will be placed on top of the folding structure. Railings will be attached to the middle bridge members

Design Calculations & Decisions

Material Selection: Folding Structure Members

- Assumptions/Previously determined values
- Max 1000 lb force on any given member
- ¼" thickness, square cross section (2"x2")
- Desired factor of safety = 2

$$E = \frac{PL^3}{48Id} = \frac{(1000 \text{ lb})(34 \text{ in})^3}{(48)(0.77 \text{ in}^4)(0.25 \text{ in})} = 4,265,691 \text{ psi}$$

- Aluminum 6061-T6 was chosen (E = 9,863,000 psi)

Material Selection: Joint Pin

- Assumptions/Previously determined values
- Max 250 lb point force at center of horizontal member
- Stress concentrations, tolerances from manufacturing and loading from impact are negligible
- Desired factor of safety = 2

$$\sum M_A = 0$$

$$-M + (125)(1.45) = 0$$

$$M = 362.5 \text{ lb} \cdot \text{in}$$

$$\sum F_y = 0$$

$$F_{outer} - V = 0$$

$$F_{outer} = V = 125 \text{ lb}$$

$$\sigma_b = \frac{Mc}{I}$$

$$I = 0.04 \text{ in}^4$$

$$c = 0.39 \text{ in}$$

$$\sigma_b = \frac{(362.5)(0.39)}{0.04}$$

$$\sigma_b = 3534.375 \text{ psi}$$

$$V = 125 \text{ lb}$$

$$\tau = \frac{F}{A} = \frac{125}{0.87 \text{ in}^2}$$

$$\tau = 143.678 \text{ psi}$$

- 304 stainless steel was chosen as for the pin ($\sigma_y = 9,863,000 \text{ psi}$)

Railing Stress Analysis:

The FEA model shows the von Mises stress affecting the railing deformation.

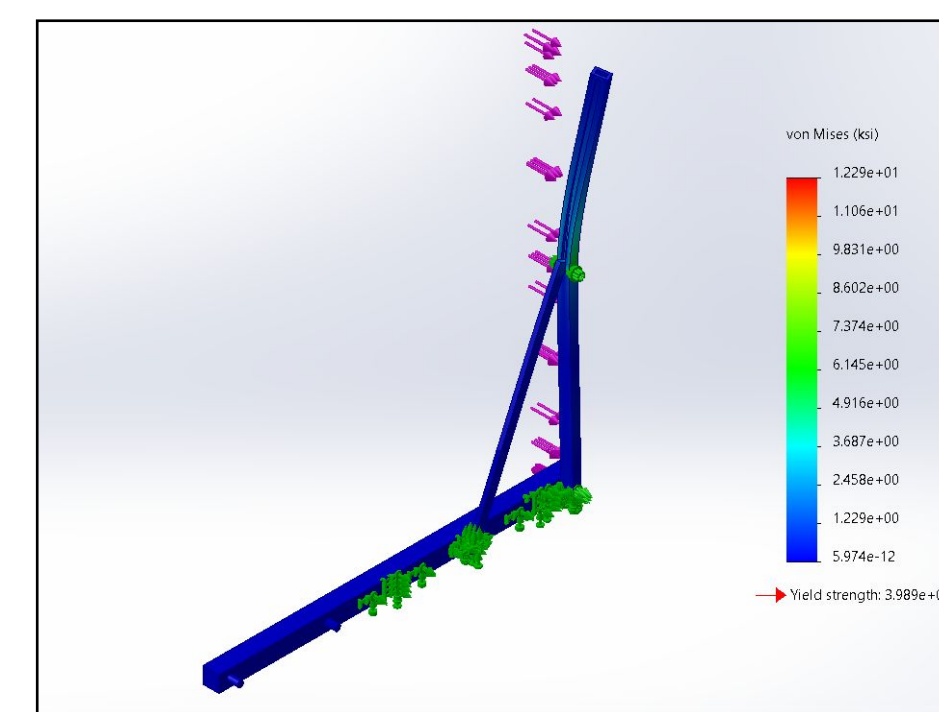

The maximum stress is 12.29 ksi based on the selected material: Aluminum 6061-T6.

Footing Material:

A 1.25-7.00 threaded rod improves the speed of height adjustment and reduces the setup time. An FEA was conducted to simulate the maximum Von Mises stress to which an Aluminum 6061-T6 threaded rod would be subjected, which was found to be well below its yield strength (55.15 MPa)

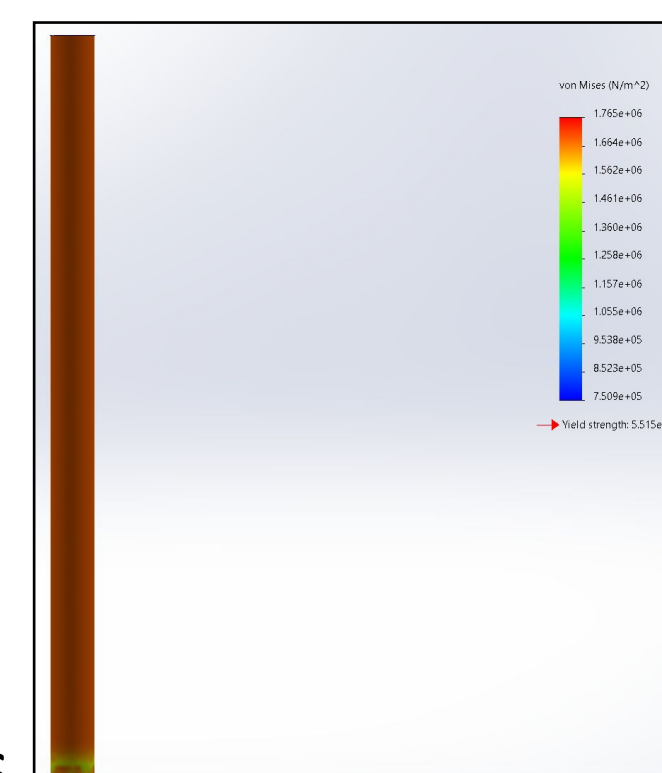

Prototype & Test Results

- ½ scale folding structure prototype (one side)
 - Parts: side members & sliding joints (inside of members)
 - Tests: Speed of deployment & take down, interference issues
 - Deployment steps:



We used a 2 part slider for prototype assembly



- Full scale locking joint prototype
 - Parts: Insert, sliding hinge, and detent pin (for locking)
 - Tests: Audible locking sounds for deployment confirmation

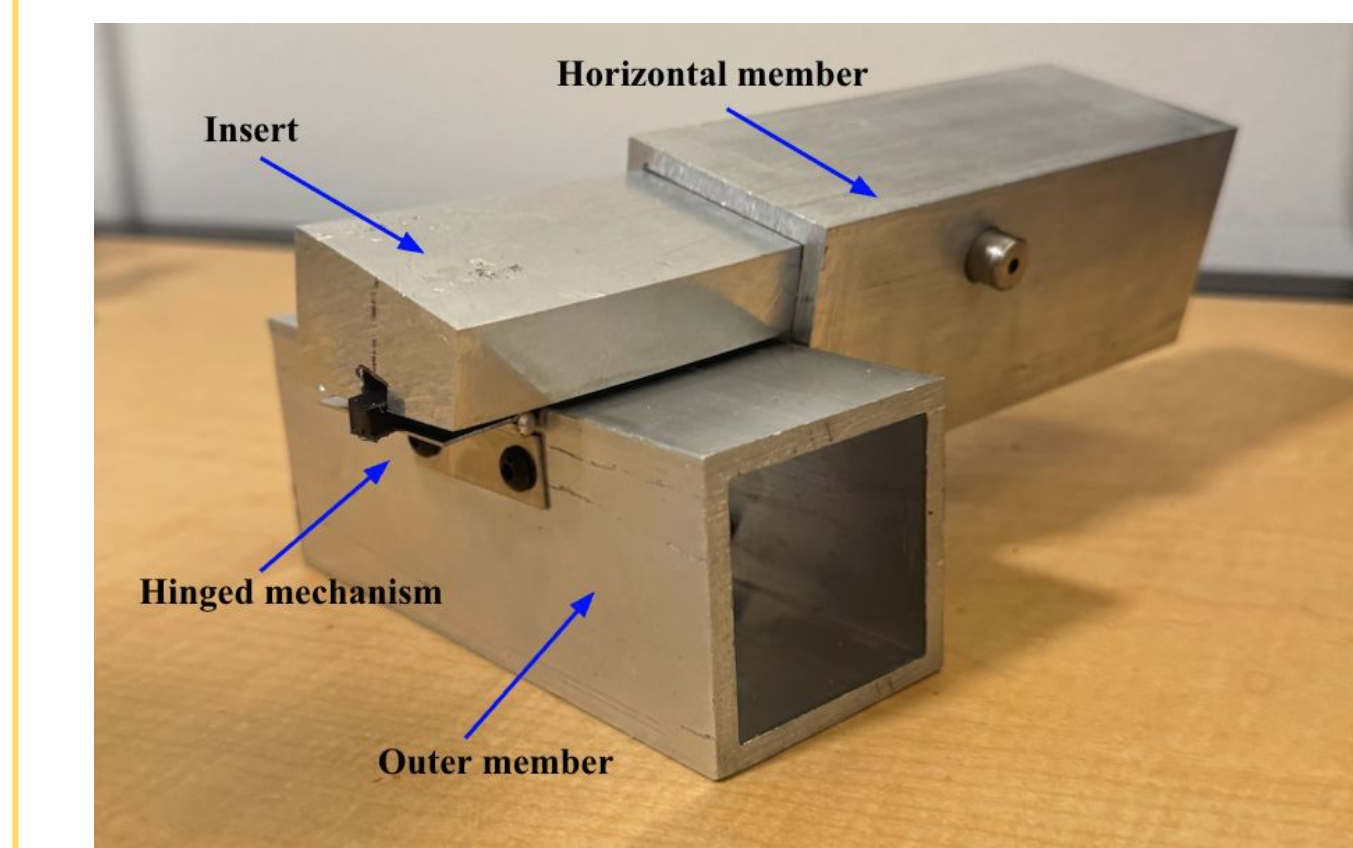

- Other prototypes test interference and compatibility between subsystems